



**Part #675 with controls**  
**Part #680 without controls**  
**Tacoma/4 Runner**  
**Electric Fan**



Custom Fits 1995-2001 Tacoma & 1996-2001 4 Runner

# Installation Instructions

**Step 1:** Remove the stock fan shroud and clutch fan assembly. Use existing bolts to secure the pulley.

**Step 2:** Locate the brackets, four long brackets and four short brackets. The brackets have different size holes. Stack a short bracket/ small hole, on top of a short bracket/ large hole. These two brackets will then make up the bracket at the top left corner of the shroud. Mount this to the shroud using  $\frac{1}{4}$ "x20 bolt and washer with a nyloc nut provided. Tighten the bolt so that the brackets can be rotated but can not move up and down. A similar bracket will go on the top right hand side of the shroud.

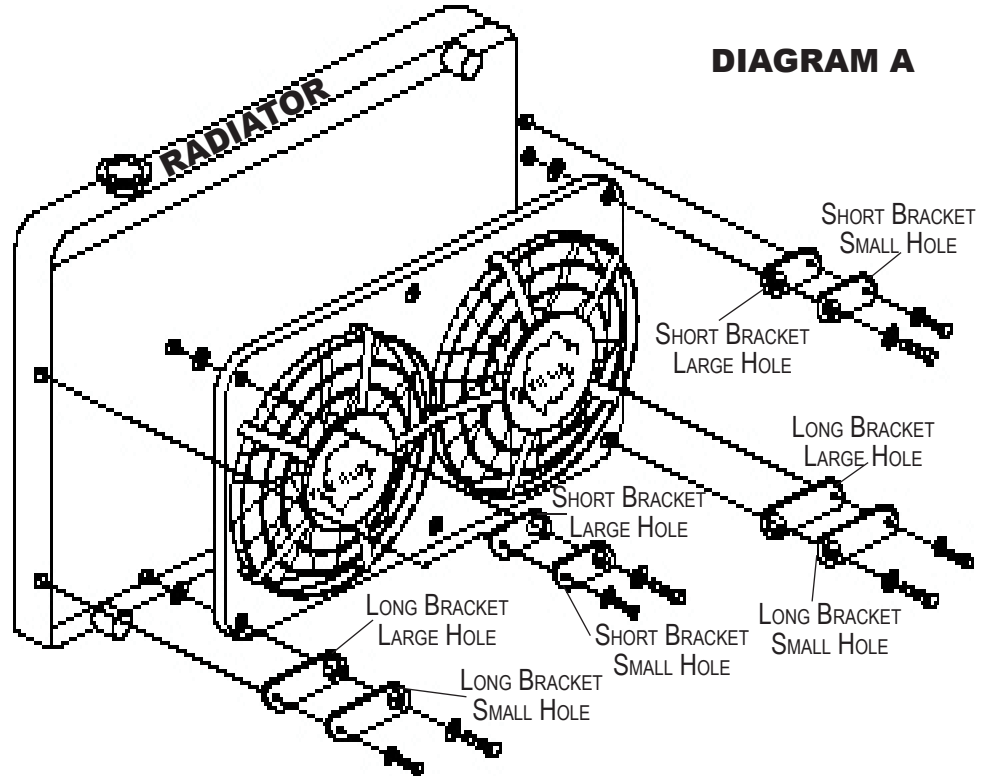

**Step 3:** Using the long brackets, make up brackets for the lower left and right hand side of the shroud. Mount the brackets to the shroud with provided bolt/washer and nut.

**Step 4:** Locate the four 6mm bolts in the kit, these will be used to mount the fan to the radiator. The brackets mount to the old shroud mounting points on the sides of the radiator. If possible, have someone hold the fan while you start the mounting bolts at the corners of the fan. Do not tighten down the bolts until you have all four corners started. Then slowly tighten a little at each corner.

**Before wiring the fans up check to see that the fan blades spin freely with out contacting the radiator or other objects.**

**Manual fan disconnect:** If you would like to be able to turn off your fan before a water crossing or other reason, you can place a Flex-a-lite #31148 Manual Switch between the '+' terminal and the 12V source. This will switch the thermostat control to the fan off, when the switch is off. Which will prevent the fan from running automatically. (You must make sure that you do not have a manual switch to the 'M' terminal or that your A/C is on). Or if so the manual switch is turned off.

**Do not use any other manual switch than Flex-a-lite # 31148. Damage to your electrical system may occur when using switches other than Flex-a-lite #31148.**

# Fan Wiring Instructions

Note: Does not apply to #680

## Step 1: Locate mounting point for control

Locate a mounting point for control near inlet side of radiator. Control needs to be placed within 18" of radiator inlet hose. You may want to mount next to radiator on fender well. Mount control using screws provided.

## Step 2: Wire the fan motors (refer to Wiring Diagram, below)

Using the bullet connectors provided, attach a length of the large diameter (12 AWG) *red* wire to the *colored* motor wires at fan. Attach a length of the large diameter (12 AWG) *black* wire to the *black* motor wires at the fan. Once the fan is in place, these will attach to the control module. If mounting the control somewhere in the engine compartment, leave enough wire to reach the control module, but do not connect yet.

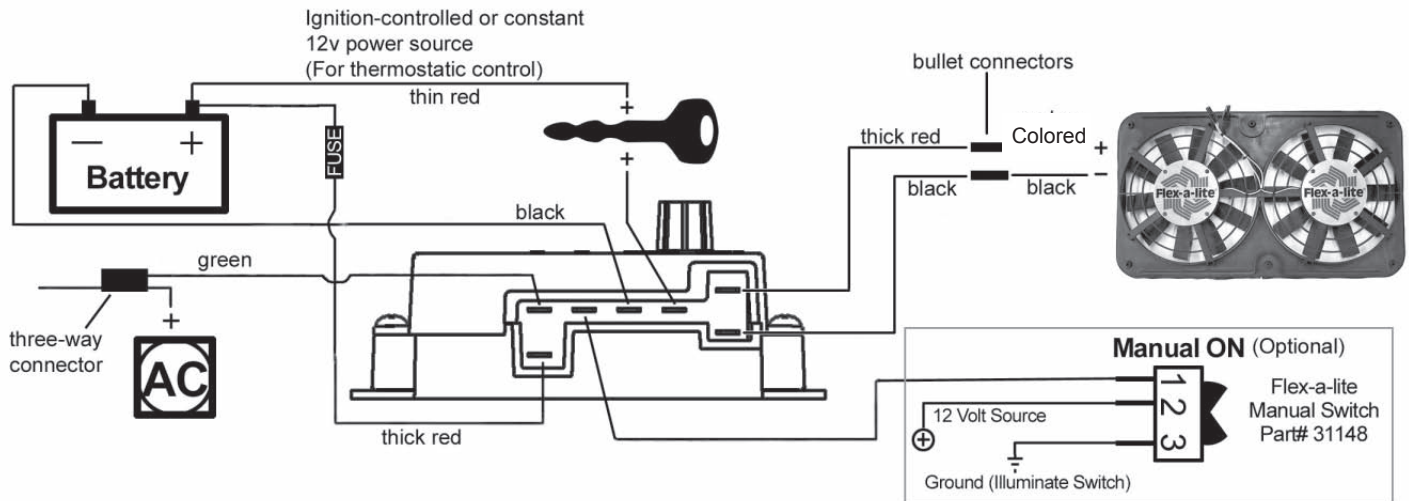

**Step 3:** Connect the motor wires to the control module using the female connectors provided. (Red wire to the "M+" terminal and black wire to the "M-" terminal).

**Step 4:** Disconnect the negative battery lead for safety while finishing the wiring. Use the large diameter red wire to run power directly from the battery positive (+) terminal to the "B" terminal on the control module. Connect the fuse holder in-line with this wire, as shown, but do not insert the fuse yet. Use the blue female, ring, and butt connectors provided.

**Step 5:** Use the large diameter black (12 AWG) wire to run from the negative (-) battery terminal to the "G" terminal on the control module. Use the blue female connector and ring connector provided.

**Step 6:** Use the small diameter red wire (14 AWG) to connect the "+" terminal on the control module to a positive power source. **NOTE: Attaching this wire to an ignition-controlled source will shut off the fan when the engine is turned off. Attach this wire to an uninterrupted (always hot) power source to allow the fan to continue running after the engine is shut off.** Use the blue female connector and fuse taps (included) if necessary.

**Step 7:** (Optional) For air conditioning control (if desired) connect the "C" terminal on the control module to the *positive* wire that triggers the A/C compressor using the small diameter green (14 AWG) wire. Using a voltmeter, determine which wire coming from the compressor is the *positive* trigger wire. Use the 3-way connector (included) to tap into this wire and send a signal to the fan control module. The fan will cycle on and off with the A/C clutch when the A/C is turned on.

**Step 8:** (Optional) For manual switch operation, use Flex-a-lite p/n 31148. Connect the switch as shown on the wiring diagram (previous page). Connect the "M" terminal on the control module to the "1" terminal on the switch. Connect the "2" terminal on the switch to a positive 12v power source. Connect terminal "3" on the switch to a good ground (for switch illumination). **NOTE: To prevent thermostatic activation (if only manual switch operation is desired), omit the lead to the "+" terminal of the control box. "B", "G", "M+" and "M-" must remain connected. If not using a Flex-a-lite manual switch, do not connect a ground wire to the switch!**

**Step 9:** Use the zip ties provided to secure the wires and prevent them from interfering with fan blades, belts, and pulleys in the engine compartment. Reconnect the battery and insert the 30 amp fuse provided.

**Step 10: Insert the temperature probe into the radiator fins**



**Install temp. probe near inlet hose...**

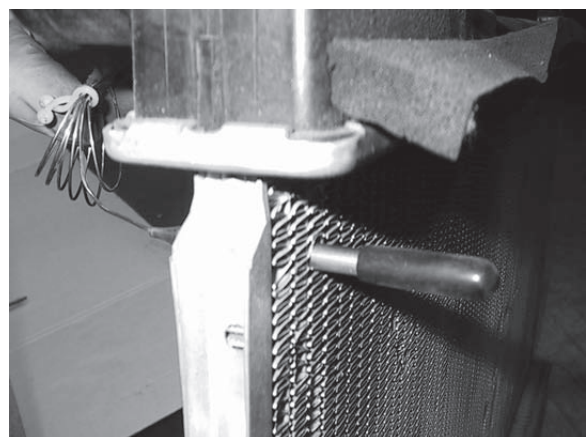

**then install the insulator cap.**

Locate the inlet hose from the engine to the radiator. Remove the black insulator cap and insert the temp. probe through the radiator fins near the inlet hose. Reinstall the black insulator cap.

**Step 11: Adjust the temperature control knob on the control box**

If you disconnected any hoses or drained coolant to install the fan, reconnect the hoses and refill the radiator. Press the control knob (included in wiring kit) onto the control box shaft. Turn the knob clockwise until it stops. Start the engine and allow it to idle. Using a digital thermometer (positioned near the inlet hose) or the vehicle's temperature gauge, monitor the temperature. When the coolant temp. is slightly above normal (or desired temp.), turn the knob counter-clockwise just until the fan turns on. From now on, the fan should activate at this temperature setting. Adjust as necessary to maintain desired temperature.

**The Flex-a-lite Limited Warranty**

Flex-a-lite Consolidated, 7213-45th St. Ct. E. Fife, WA 98424, Telephone No. 253-922-2700, warrants to the original purchasing user, that all Flex-a-lite products to be free of defects in material and workmanship for a period of 365 days (1 year) from date of purchase. Flex-a-lite products failing within 365 days (1 year) from date of purchase may be returned to the factory through the point of purchase, transportation charges prepaid. If, on inspection, cause of failure is determined to be defective material or workmanship and not by misuse, accidental or improper installation, Flex-a-lite will replace the product free of charge, transportation prepaid. **Flex-a-lite will not be liable for incidental, progressive or consequential damages.** Some states do not allow the exclusion or limitation of incidental or consequential damages, so the above limitation or exclusion may not apply to you. This warranty gives you specific legal rights and you may have other rights, which vary from state to state. The Flex-a-lite warranty is in compliance with the Magnuson-Moss Warranty Act of 1975.