



Zinc Radiator Anode

#32060



Note: Always read instruction and verify kit contents prior to installation.
Zinc Anode..... 1 ea.

Flex-a-lite has developed a zinc anode kit to be installed in the radiator as a replacement for the drain petcock in radiators that are equipped with a 1/4" NPT bushing welded into the tank. Or it can be installed in any 1/4" NPT hole that is available in the cooling system.

For years Anodes have been used in Heavy Duty and Marine applications to protect the cooling systems and its many components from damage due to electrolysis or coolant additive failure/ breakdown. In some cases other corrosive material used in manufacturing and remanufacturing of engine parts and components.

Flex-a-lite now brings this protection to you. Today's cars and trucks have many aluminum parts and parts made in combination with aluminum alloy. Aluminum parts may disintegrate from electrolysis in the cooling system. The introduction of the zinc anode will protect your cooling system from galvanic action "Eats" the zinc rather than your cooling system.

INSTALLATION INSTRUCTIONS

1. **BE SURE THE ENGINE IS COOL BEFORE PROCEEDING.**
2. Verify the radiator being worked on has a 1/4" NPT drain petcock or an available 1/4" NPT hole. Remove petcock or applicable plug.
3. Wrap brass threaded portion of anode with Teflon tape or sealing compound. Screw into radiator. **DO NOT OVER TIGHTEN.** Refill coolant if necessary and verify that no leaks are occurring with vehicle sitting or while engine is running.
4. Check Anode every 12 months; replace when anode is 80% consumed.

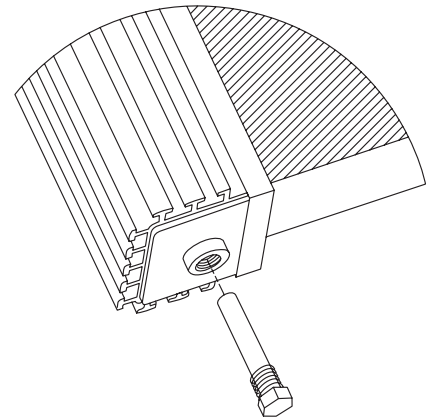

Note: Visit our website www.flex-a-lite.com to register product for warranty and review warranty policy.

Note: For questions regarding mounting of this product, call 1-877-767-0554 for assistance.

The Flex-a-lite Limited Warranty
Flex-a-lite Consolidated, 7009-45th St. Ct. E. Fife, WA 98424, Telephone No. 253-922-2700, warrants to the original purchasing user, that all Flex-a-lite products to be free of defects in material and workmanship for a period of 365 days (1 year) from date of purchase. Flex-a-lite products failing within 365 days (1 year) from date of purchase may be returned to the factory through the point of purchase, transportation charges prepaid. If, on inspection, cause of failure is determined to be defective material or workmanship and not by misuse, accidental or improper installation, Flex-a-lite will replace the product free of charge, transportation prepaid. Flex-a-lite will not be liable for incidental, progressive or consequential damages. Some states do not allow the exclusion or limitation of incidental or consequential damages, so the above limitation or exclusion may not apply to you. This warranty gives you specific legal rights and you may have other rights, which vary from state to state. The Flex-a-lite warranty is in compliance with the Magnuson-Moss Warranty Act of 1975.