

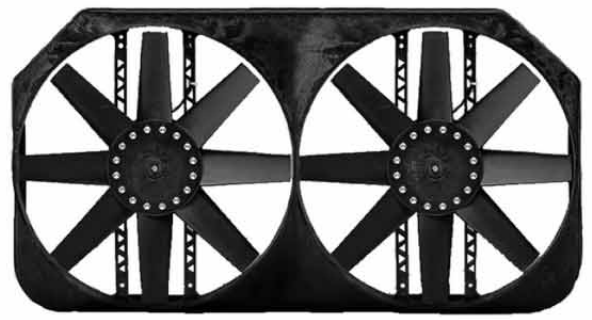

# 280



# Monster Fan

## Fits 1992-1999 GM

## Full-Size Trucks/SUV with 34" radiator

# INSTALLATION INSTRUCTIONS

### REMOVE EXISTING FAN & SHROUD ASSEMBLY:

1. Remove plastic radiator cover and top half of fan shroud.
2. Remove fan and clutch assembly. If clutch is mounted to the pulley, replace the nuts or bolts that hold the pulley on after clutch removal. The clutch may be mounted with a large single nut. It may be possible to remove this clutch by fitting a large wrench to the nut. Put a rag over the fan to avoid personal injury. Hold the fan in place and pull the wrench in the direction of rotation. It may help to give the end of the wrench a sharp strike from a soft-blow hammer to break the nut free without the pulley slipping.
3. Remove the lower shroud.
4. Determine if you have a 17" tall or 19" tall radiator by measuring the height of the core/ fin area. Also make sure the radiator is a minimum of 32" or greater in length of core/fin area.



### MOUNTING AND WIRING THE VARIABLE SPEED CONTROL (VSC):

1. The VSC can be mounted on the front face on the shroud. Using the VSC as a template, mark locations for two holes, then drill  $\frac{5}{32}$ " holes for mounting the control onto the shroud. Use the two screws provided in the VSC kit (*see Detail 1*).
2. Drill two  $\frac{1}{4}$ " holes to the left of the VSC to pass the yellow and purple wires through to the back side of the shroud (*see Detail 1*). Drill one  $\frac{1}{4}$ " hole in the support rib on the back side of the shroud to pass the motor wires through (*see Detail 2*).
3. Strip back all 4 motor wires so  $\frac{3}{8}$ " bare wire is exposed. Locate both red motor wires and twist together tightly. Locate both black motor wires and twist together tightly. Crimp a yellow butt connector to red wires, then repeat with the black wires. **The red motor wire is (+) positive and the black is (-) negative.**
4. Feed the thick purple and yellow wires from the control unit through the holes you drilled in step 2. ***Crimp the yellow wire to the two red motor wires, and the purple wire to the two black motor wires.*** Zip tie the wires so that they are clear of the fan blade (*see Detail 3*).
5. Wrap the connections with electrical tape (not provided) to seal them from moisture and dirt.

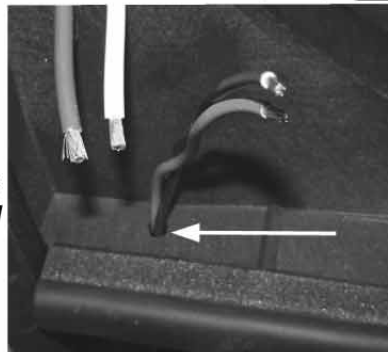
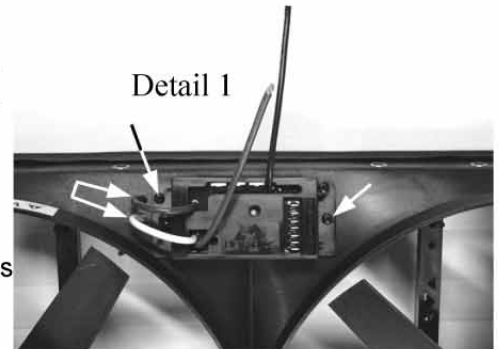

Detail 2

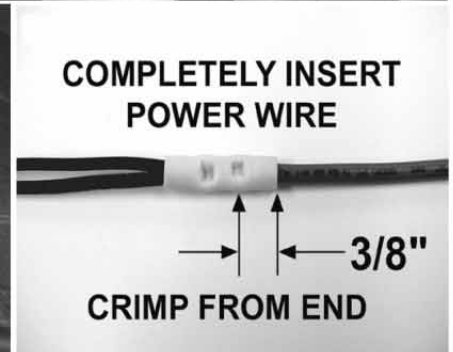

Detail 3

### INSTALL THE ELECTRIC FAN ASSEMBLY:

1. Select the type of brackets needed for your vehicle.
2. Loosely assemble the correct top bracket to the top of the shroud, the 17" brackets are 2 pieces, the 19" bracket is a single piece.
3. Temporarily mount the fan using the top bracket only. Adjust the bracket so the fan is sealed to the core.
4. The bottom brackets will need to be custom mounted due to the number of variations in GM shroud mounting points from 92-99. Measure the thickness of the radiator core. If it is less than  $1\frac{1}{2}$ " then use the 1 row brackets (#28001), if greater than  $1\frac{1}{2}$ " use the 2 row brackets (#28002). Loosely mount the bracket to the lower tray, using the same mounting points as the OEM shroud. Compress the seal of the fan against the core. With a marking pen, mark where to drill a  $\frac{1}{4}$ " hole for mounting the brackets to the shroud.
5. Remove the fan unit and drill the  $\frac{1}{4}$ " holes for the bottom brackets, then mount the brackets using the screws and nuts supplied in the kit.

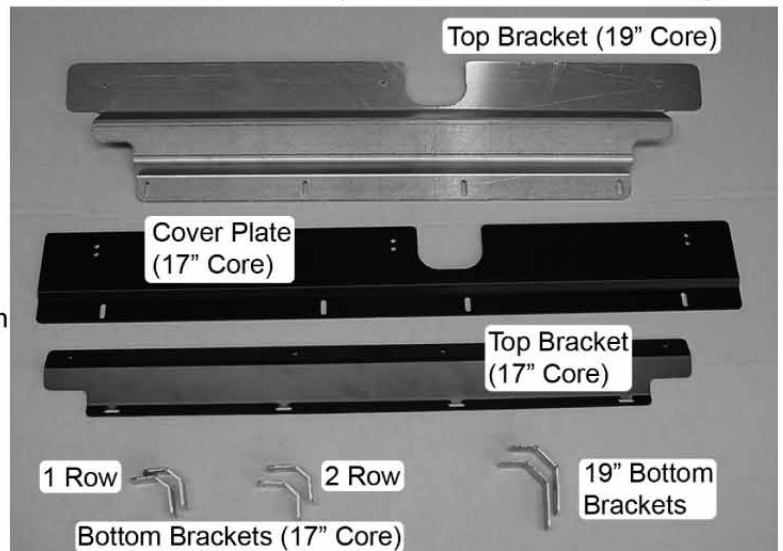

#### The Flex-a-lite Limited Warranty

Flex-a-lite Consolidated, 7213-45th St. Ct. E., Fife, WA 98424, Telephone No. 253-922-2700, warrants to the original purchasing user, that all Flex-a-lite products to be free of defects in material and workmanship for a period of 365 days (1 year) from date of purchase. Flex-a-lite products failing within 365 days (1 year) from date of purchase may be returned to the factory through the point of purchase, transportation charges prepaid. If, on inspection, cause of failure is determined to be defective material or workmanship and not by misuse, accidental or improper installation, Flex-a-lite will replace the fan free of charge, transportation prepaid. Flex-a-lite will not be liable for incidental, progressive or consequential damages. Some states do not allow the exclusion or limitation of incidental or consequential damages, so the above limitation or exclusion may not apply to you. This warranty gives you specific legal rights and you may have other rights, which vary from state to state. The Flex-a-lite warranty is in compliance with the Magnuson-Moss Warranty Act of 1975.

- With the fan assembly in place, make sure the seal is contacting the core and compress the seal about 50%. Tighten the brackets.

## -----WIRING INSTRUCTIONS-----

### WIRING CONNECTIONS

- |                                   |                                   |
|-----------------------------------|-----------------------------------|
| #1 Battery Negative* (BLACK)      | #8 A/C Compressor Positive Signal |
| #2 Negative to Fan* (PURPLE)      | #9 Ignition Positive Signal*      |
| #3 Positive to Fan* (YELLOW)      | #10 Temp Sensor Wire*             |
| #4 Battery Positive* (RED)        | #11 Temp Sensor Wire*             |
| #5 Negative Override Signal OFF   | L1 Fan Output Indicator           |
| #6 Negative Override Signal ON    | L2 Override Condition Indicator   |
| #7 A/C Compressor Negative Signal | L3 A/C Signal Indicator           |
|                                   | L4 Ignition Signal Indicator      |

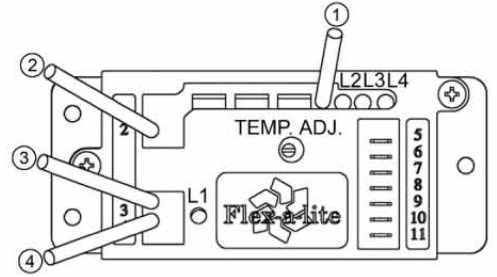

\* mandatory connections

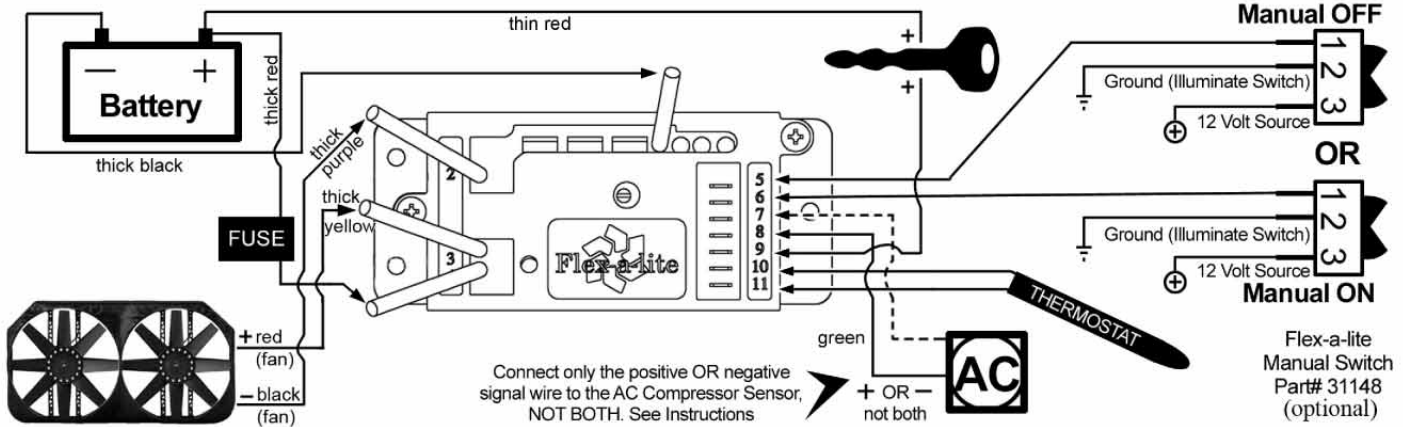

- Find the thick red and black wire in the kit. Determine the length needed to connect the red and black power leads on the VSC to the battery terminals and trim appropriately. Crimp a large yellow ring connector to the end of the black wire and connect to the negative (-) battery terminal. Connect the other end to the black wire on the VSC with a large butt connector (yellow sleeve).
- Locate the fuse holder. **DO NOT INSTALL THE FUSE UNTIL ALL THE WIRING IS COMPLETE.** Attach a large ring connector to one end and a yellow insulated butt connector to the other end of the fuse holder. Attach the ring connector to the positive (+) terminal of the battery and connect the other end to the thick red wire found in the kit. Determine the length of wire needed to reach from the fuse holder to the red wire on the VSC and trim appropriately. Use a yellow insulated butt connector to connect this wire to the red wire on the VSC. You may use the 2 small screws to mount the fuse holder if desired.
- Find a circuit that is "hot," preferably in a fuse box, when the key is in the "ON" position. Attach the included fuse tap to fuse. Attach a pink female connector to one end of the thin red wire (included) and connect to fuse tap. Determine length of wire needed to reach VSC and trim to appropriate length. Attach a pink female connector to the end of the wire and connect to terminal #9 on VSC.
- Locate wires going to A/C clutch. Determine which wire is ground and which is positive. Then attach supplied thin green wire by way of a piggyback connector to the positive wire that activates clutch. Attach wire to **terminal #8** on the VSC. Terminal #7 will be left open for this application.
- Locate temperature probe. Gently push the probe through fins in radiator as close to the upper radiator hose as possible with  $\frac{1}{4}$ "- $\frac{1}{2}$ " of the probe protruding out of the front of the core. Install the rubber cap on the front side of the probe (if possible). This will give the VSC the most accurate engine temperature reading. Determine length of wire needed to reach VSC. **IMPORTANT:** Strip the insulation on the temperature probe wires back about 1" and fold the wire on itself to effectively double the thickness of the wire before connecting spade connectors. Then attach these wires to terminals #10 & #11. Both wires need to be connected, but it doesn't matter which wire goes to each terminal.
- If manual switches (Flex-a-lite #31148) have been purchased, attach them as following. To override engine temperature to turn fans off, connect the switch to terminal #5 on VSC to send a ground signal. To override engine temperature to turn fans on, connect the switch to terminal #6 on the VSC so that a ground signal is sent.

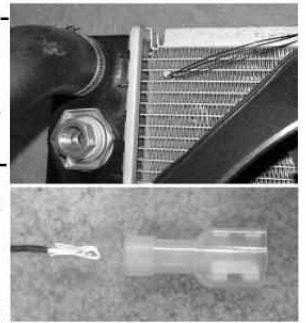

### Initial Set-up and Adjustment

- Turn ignition on. After 5-6 seconds, LED #4 should light up. If not, check to make sure that you have 12 Volts at terminal #9 on VSC. The delay is to allow starter to start the vehicle without the fans drawing any power.
- With your engine running, engage the A/C. Your fans should come on and cycle with the A/C clutch. LED's #1, 3 and 4 should be lit when fans are running. If they do not turn on, verify that the A/C clutch is engaged and make sure that you have the appropriate wire connected to correct terminal on the VSC. Shut off A/C and let engine continue to idle until you reach operating temperature.
- Verify that operating temperature has been reached by feeling upper radiator hose. Hot water should be flowing through hose into the radiator. Adjust the screw on the VSC counterclockwise for a cooler setting or clockwise for a warmer setting. Once desired temperature is set, let engine continue to idle to make sure the fans will cycle to maintain desired temperature. When fans are running, LED's #1 and 4 should be lit.

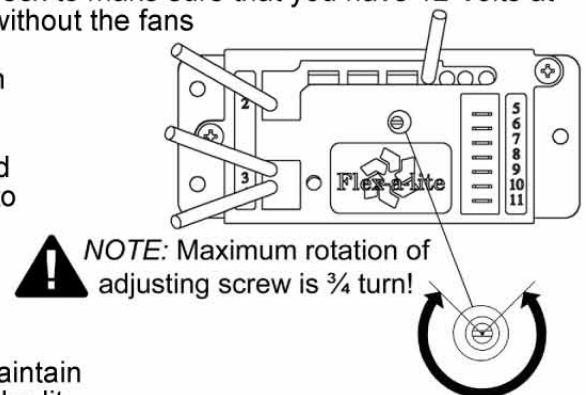

### The Variable Speed Control has new features!

**When you set the on temperature, the fans will come on at 60%; this reduces the load on your charging system. If the temperature rises, the fan speed will increase. If your set temperature is 185° F, then between 185° and 195° the fan speed will increase from 60% to 100%. So after a 10° rise from the set point, the fans will be running at 100%.**